

8.43 E



Rotary rack oven Electric

Capacity

- Rack oven for 460 x 800 or 400 x 800 mm tray size.
- 108 baguettes of 250 g or 200 little breads of 60 g on 18 levels.
- 60 breads of 400 g on 15 levels.

Characteristics

- Rack driving by turntable
- Door handle left (standard) right (to be specified at time order).
- 3 types of control.
- Front with headband or steam exhaust hood.
- 2 speed of ventilation on option for baking fine pastry.
- Hood display on option for UNICOM 2 control.

General features

- Stainless steel baking chamber.
- Stainless steel electric resistances with 3 years warranty
- Retractable access ramp for a perfect and durable door tightness
- Ergonomic handle, over-dimensioned hinges, ventilated double-glazing guarantee perfectly the door functions (reliability, insulation, safety).
- Steam generator composed of structured gutters in cast-iron.
- Steam exhaust system with 2 electric valves which empty automatically the chamber at the end of baking cycle.
- Performant insulation by crossed rock wool panels.
- Electrical clusters of high temperature silicone wires.

- Oven complies with  regulations

Standard oven

- Door handle on the left hand side
- Opticom controls on the left hand side
- Head band

Reference	Oven
75500043	8.43 E

Options

Door handle on the right hand side

Electromechanical controls

UNICOM 2 controls

Exhaust fan for electromechanical controls





Hood without display

2 speed ventilation for UNICOM 2 or electromechanical controls

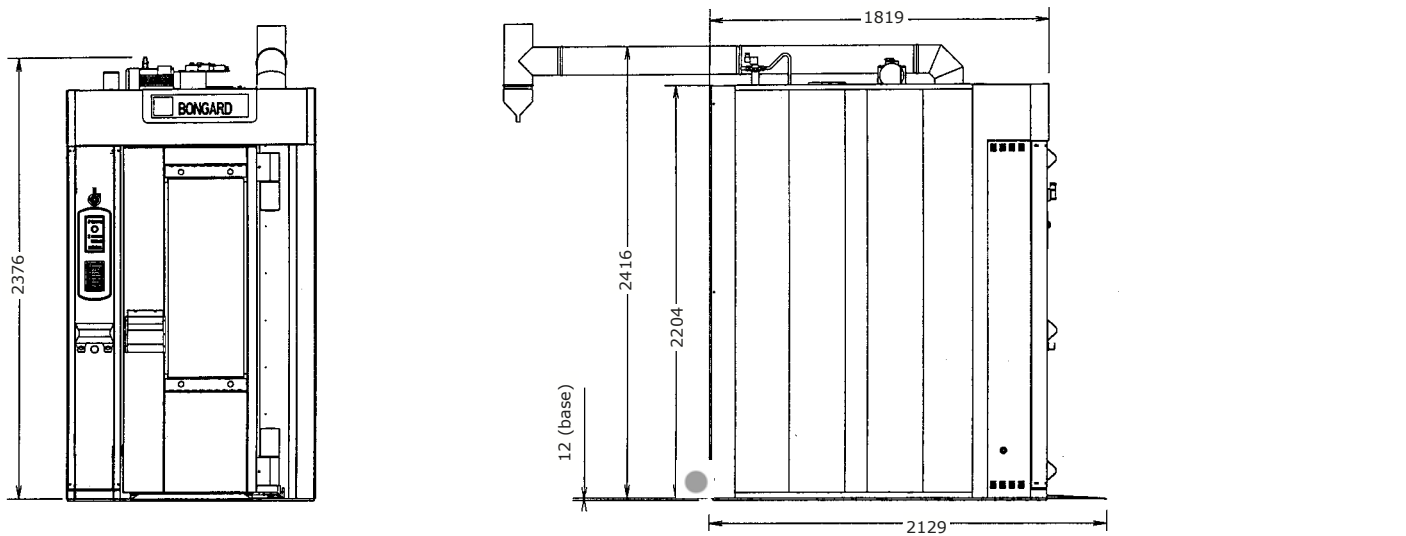
Hanging system for racks

Rotary rack oven 8.43 E



-  Electrical connection from top : see energy characteristics above
-  Caution cold water connection from top, water tap in waiting position
h = 2500 mm. Ø 3/8" – 12/14 mm, 2.5 – 4 bars pressure
-  Steam exhaust connection, h = 2400 mm, Ø 150 mm. Draught
between 0,1 and 0,4 mbars
-  Steam generator drain, h = 65 mm, Ø 3/4"
-  Hood option : smoke exhaust connection, h = 2500 mm, Ø 200 mm,
steam exhaust fan included 800 to 1100 m3/h

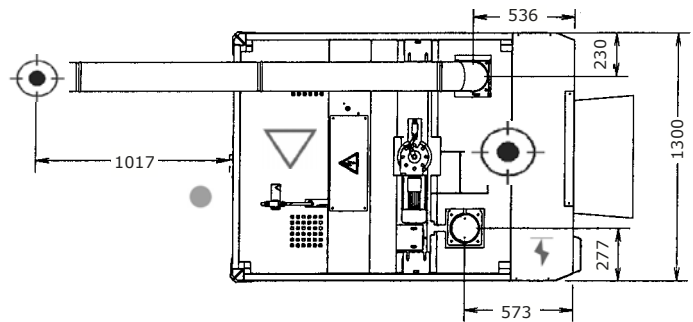

Required technical access on the top of the oven = 350 mm.

General characteristics

Height, width, depth : see the drawing

Floor area	2,3 m ²
Total weight	940 kg
Baking chamber	
Useful height	1 785 mm
Ø maximum rotation	950 mm
Hook rotation speed	5 tr/min
Maximum weight to be carried by the hook	200 kg
Minimum space required for building	920 mm

Energy characteristics

Electric power	
Motors/lighting	0,65 kW
Exhaust (option)	0,12 kW
Valves + miscellaneous	0,03 kW
Total	0,8 kW
Electric heating power (indicative)	36 kW
Connection power	38 kW
Electrical supply	400/230 V 3 PH + N/50 Hz
Average gradient of temperature rise	10 to 12°C/min
Maximum baking temperature of the oven	300°C

Specifications of baking trays

Type of products	Number of pieces	Levels	Spacing	Type of trays	Dimensions	Baking area
Baguettes 200 g	108	18	89	6 AL 800	460 x 800 mm	6,6 m ²
	90	18	89	5 AL 800	400 x 800 mm	5,8 m ²
Baguettes 250 g	108	18	89	6 AL 800	460 x 800 mm	6,6 m ²
	90	18	89	5 AL 800	400 x 800 mm	5,8 m ²
	90	15	104	6 AL 800	460 x 800 mm	5,5 m ²
	75	15	104	5 AL 800	400 x 800 mm	4,8 m ²
Loaves 400 g	60	15	104	4 AL 800	400 x 800 mm	4,8 m ²
	48	12	130	4 AL 800	400 x 800 mm	3,8 m ²
Danish		18	89	Flat tray	400 x 600 mm	4,3 m ²
		15	104	Flat tray	400 x 600 mm	3,6 m ²

Rack specifications

	Height	Width	Depth
400 x 800 standard	1790 mm	450 mm	825 mm
460 x 800	1790 mm	510 mm	825 mm